

Fahrgestell

Chassis
Châssis

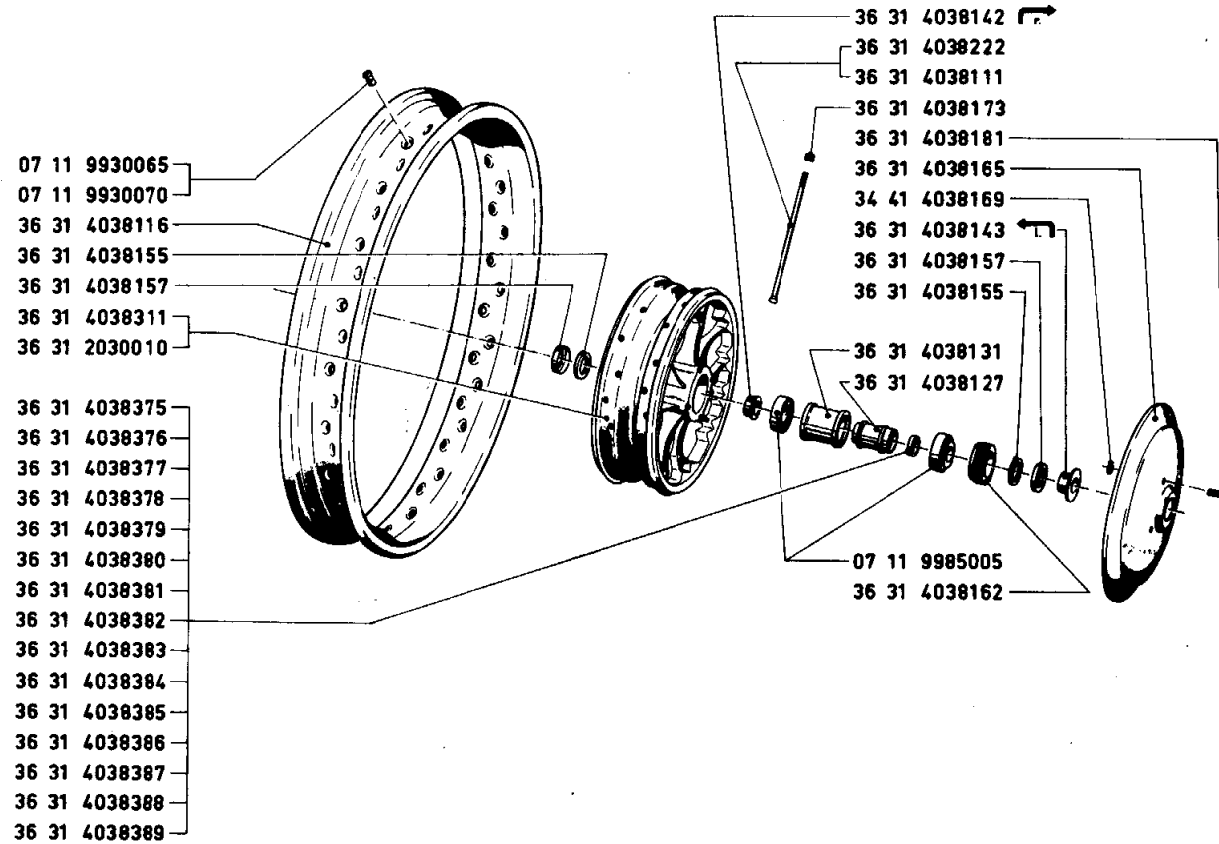

36 31 4038014



R 26
R 27

Fahrgestell	- Räder mit Lagerung
Chassis	- Wheels with bedding
Châssis	- Roues avec logement

36.3

1/1

1.9.1968

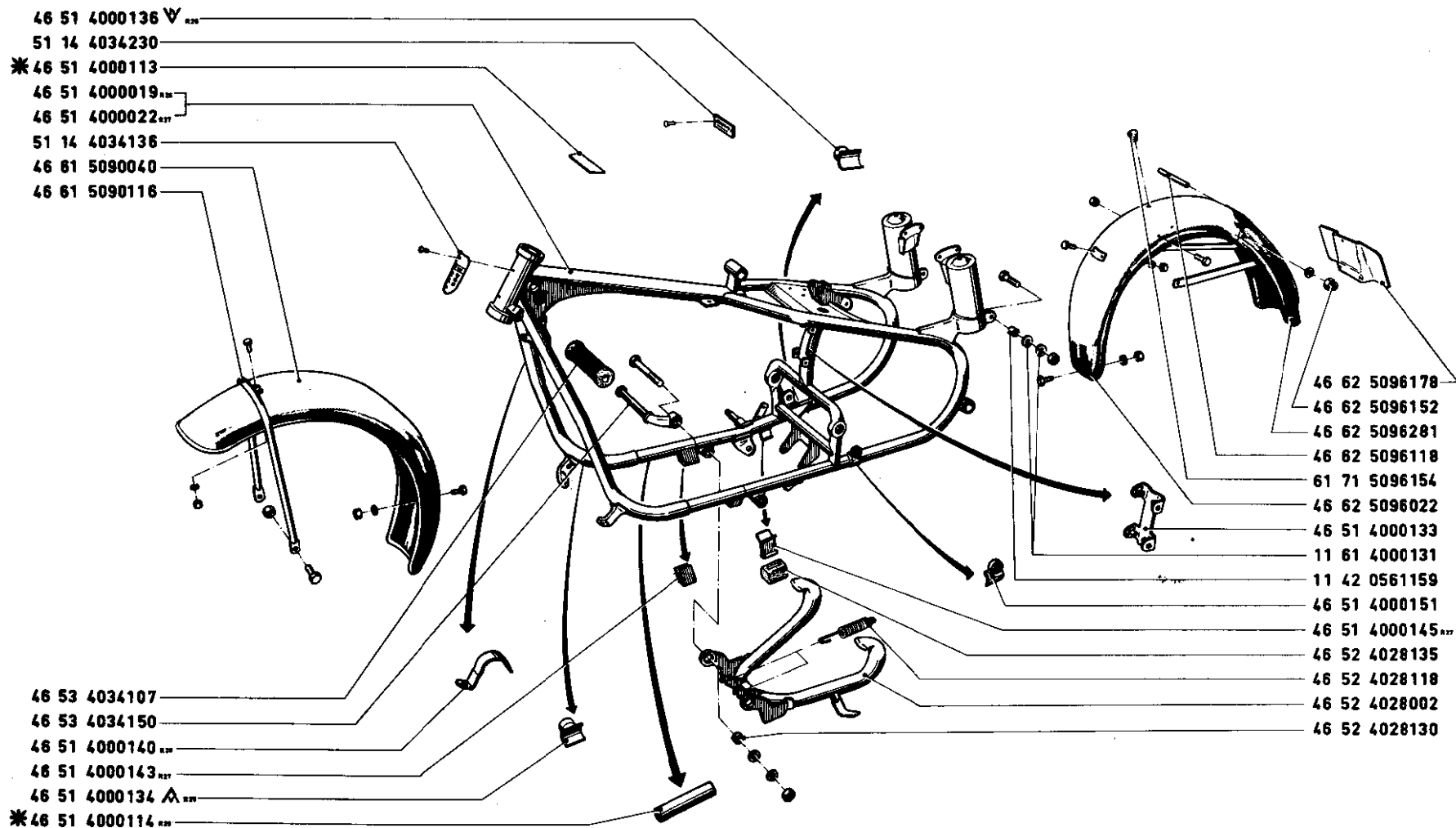

R 26
R 27

Fahrgestell - Rahmen, Schutzbleche
Chassis - Frame, fenders
Châssis - Cadre, étrier de garde

46.5+46.6

1/2

1.9.1968



Fahrgestell - Rahmen, Schutzbleche
 Chassis - Frame, fenders
 Châssis - Cadre, etrier de garde

46.5+46.6

Anderungen
 Modifications
 Modifications

1/2

1.9.1968

Anderung Nr.	Teil-Nr.	Stück/E				Sym- bol	Teil-Benennung	Denomination of parts	Dénomination de pièces	Anderung Nr.	Teil-Nr.	Bemerkungen
		R 26	R 27									
	11 42 0561159	2	2				Büchse	Bushing		*	46 51 4000113	für Rep. Batterie und Luffilterkastenhalterung (R 26 + R 27)
	11 61 4000131	4	4				Scheibe	Washer				
	46 51 4000019	1					Rahmen	Frame				
	46 51 4000022	1					Rahmen	Frame				
*	46 51 4000113	1	1				Versteifungssteg	Reinforcement web		*	46 51 4000114	für Rahmenbruch bei Kippständerauflage (R 26)
*	46 51 4000114	2					Rohrstück	Tube piece				
	46 51 4000133	1	1				Halter für Batterie und Luft- filterkasten	Bracket for battery and air filter case				
	46 51 4000134	1			▲		Kugelbolzen, unten	Ball stud, upper				
	46 51 4000136	1			▼		Kugelbolzen, unten	Ball stud, upper				
	46 51 4000140	1					Halteblech für Signalhorn	Retaining plate for signal horn				
	46 51 4000143		2				Auflageblech	Supporting plate				
	46 51 4000145		1				Anschlag für Kippständer	Stop for center stand				
	46 51 4000151	1	1				Lappen für Sozjus Fußraste	Flap for pillion foot rest				
	46 52 4028002	1	1				Kippständer	Center stand				
	46 52 4028118	2	2				Zugfeder	Tension spring				
	46 52 4028130	2	2				Distanzrohr	Spacer tube				
	46 52 4028135	2	2				Anschlaggummi	Stop rubber				
	46 53 4034107	2	2				Muffe für Fußraste	Rubber for foot rest				
	46 53 4034150	2	2				Fußraste	Foot rest				
	46 61 5090040	1	1				Vorderradschutzblech	Front fender				
	46 61 5090116	1	1				Schutzblechbügel	Fender bow				
	46 62 5096022	1	1				Hinterradschutzblech	Rear fender				
	46 62 5096118	1	1				Schamierachse	Hinge bolt				
	46 62 5096152	2	2				Hutmutter	Cup nut				
	46 62 5096178	1	4				Halteblech Kennzeichenleuchte	Retaining plate license plate light				
	46 62 5096281	1	1				Hinterradschutzblech Hinterteil	Rear fender rear part				
	51 14 4034136	1	1				Typenschild, neutral	Name plate, neutral				
	51 14 4034230	1	1				Versorgungsschild (Bundeswehr)	Supply plate (German army)				
	61 71 5096154	4	4				Verschlußstopfen	Plug				

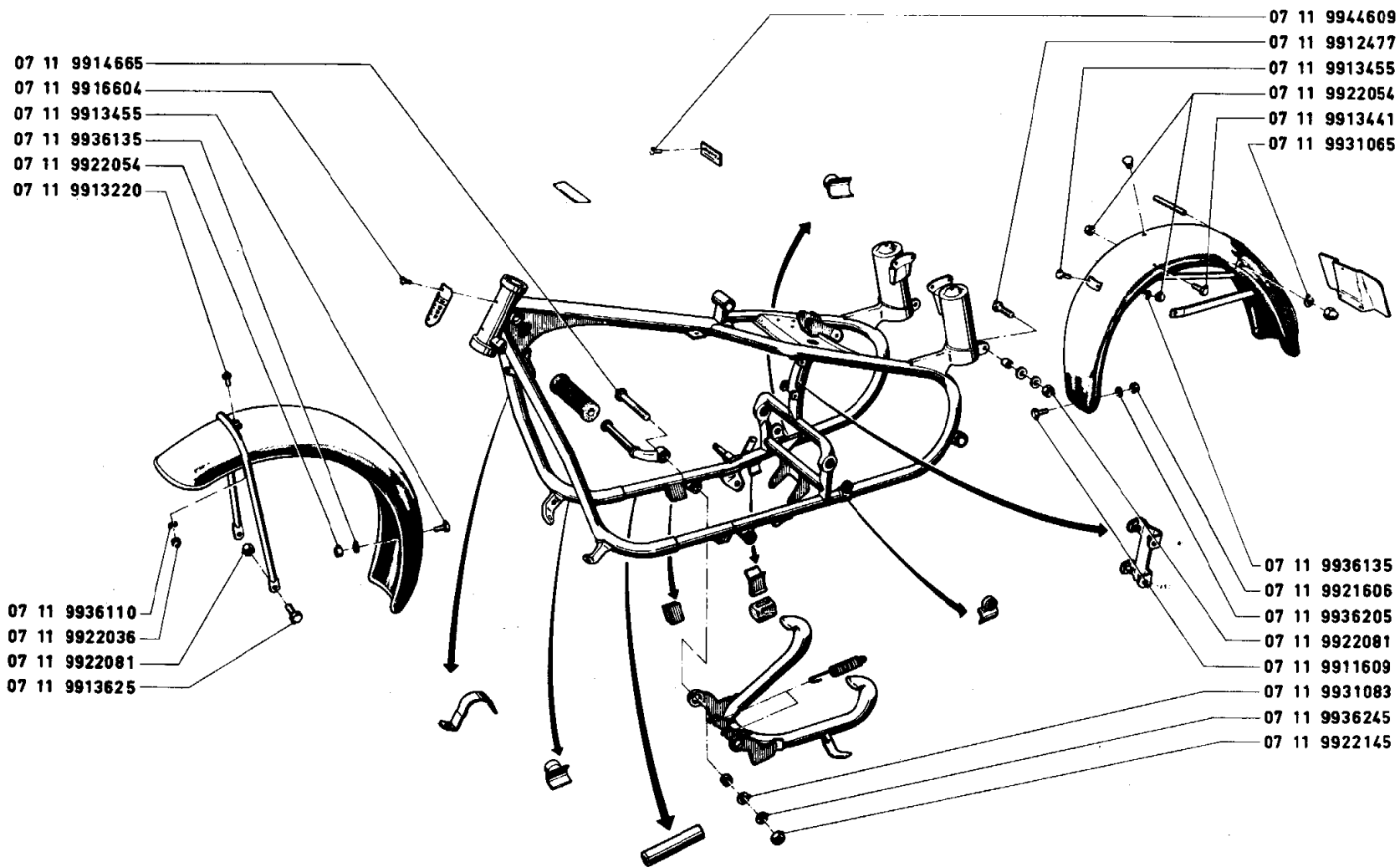

R 26
R 27

Fahrgestell - Rahmen, Schutzbleche
Chassis - Frame, fenders
Châssis - Cadre, étrier de garde

46.5+46.6

2/2

1.9.1968



Fahrgestell - Rahmen, Schutzbleche
 Chassis - Frame, fenders
 Châssis - Cadre, etrier de garde

46.5+46.6

Anderungen
 Modifications
 Modifications

2/2

1.9.1968

Änderung Nr.	Teil-Nr.	Stück/E				Sym- bol	Teil-Benennung	Denomination of parts	Dénomination de pièces	Änderung Nr.	Teil-Nr.	Bemerkungen
		R 26	R 27									
	07 11 9911609	1	1				Sechskantschraube M 8 x 1 x 15	Hex. head screw M 8 x 1 x 15	Vis à six pans M 8 x 1 x 15			
	07 11 9912477	2	2				Sechskantschraube M 8 x 35	Hex. head screw M 8 x 35	Vis à six pans M 8 x 35			
	07 11 9913220	2	2				Sechskantschraube M 5 x 10	Hex. head screw M 5 x 10	Vis à six pans M 5 x 10			
	07 11 9913441	4	4				Sechskantschraube M 6 x 12	Hex. head screw M 6 x 12	Vis à six pans M 6 x 12			
	07 11 9913455	4	4				Sechskantschraube M 6 x 15	Hex. head screw M 6 x 15	Vis à six pans M 6 x 15			
	07 11 9913625	2	2				Sechskantschraube M 8 x 18	Hex. head screw M 8 x 18	Vis à six pans M 8 x 18			
	07 11 9914665	2	2				Sechskantschraube M 12 x 1,5 x 82	Hex. head screw M 12 x 1,5 x 82	Vis à six pans M 12 x 1,5 x 82			
	07 11 9916604	2	2				Halbrundschräube AM 5 x 6	Round head screw AM 5 x 6	Vis demi - ronde AM 5 x 6			
	07 11 9921606	1	1				Sechskantmutter	Hex. nut	Ecrou à six pans			
	07 11 9922036	2	2				Sechskantmutter M 5	Hex. nut M 5	Ecrou à six pans M 5			
	07 11 9922054	8	8				Sechskantmutter M 6	Hex. nut M 6	Ecrou à six pans M 6			
	07 11 9922081	4	4				Sechskantmutter M 8	Hex. nut M 8	Ecrou à six pans M 8			
	07 11 9922145	2	2				Sechskantmutter M 12 x 1,5	Hex. head screw M 12 x 1,5	Ecrou à six pans M 12 x 1,5			
	07 11 9931065	2	2				Scheibe 8,4	Washer 8,4	Disque 8,4			
	07 11 9931083	4	4				Scheibe 13	Washer 13	Disque 13			
	07 11 9936110	2	2				Zahnscheibe J 5,3	Shakeproof washer J 5,3	Disque denté J 5,3			
	07 11 9936135	8	8				Zahnscheibe J 6,4	Shakeproof washer J 6,4	Disque denté J 6,4			
	07 11 9936205	3	3				Zahnscheibe J 8,4	Shakeproof washer J 8,4	Disque denté J 8,4			
	07 11 9936245	2	2				Zahnscheibe J 12,5	Shakeproof washer J 12,5	Disque denté J 12,5			
	07 11 9944609	2	2				Kerbnagel 1,4 x 6	Notched nail 1,4 x 6	Clou cannelé			



52 51 7002009
52 51 7002116



52 51 7002123
52 51 7002137
07 11 9931655
07 11 9922121
07 11 9936225
52 51 7002141
07 11 9914364
07 11 9921615
07 11 9923414
07 11 9945106

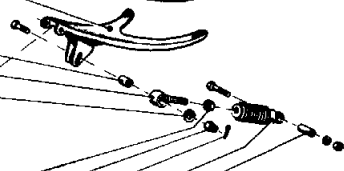

52 51 7002102
52 21 7002124
52 53 9034021
52 53 9034020(USA)
52 53 9034116
52 53 9034117

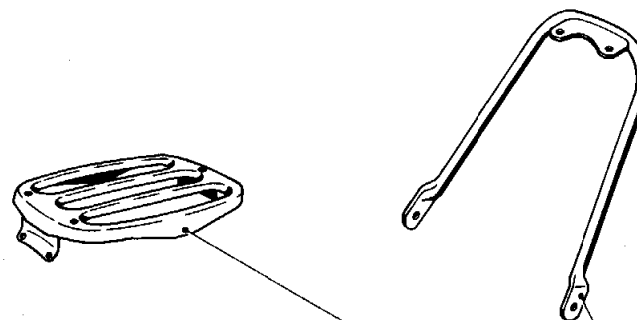
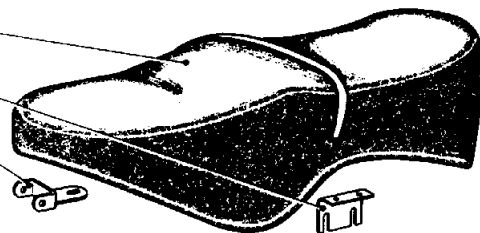

46 54 5096136
46 54 5096200
52 51 9034015
07 11 9914057

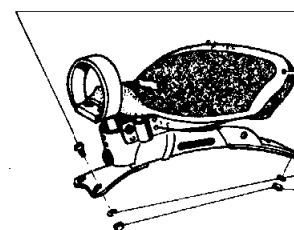
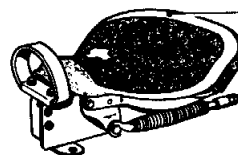

52 51 9034017
07 11 9913457
07 11 9913471
07 11 9936135
07 11 9922054

R 26
R 27

Fahrgestell - Sattel und Sitzbänke
Chassis - Seat and seat bench
Châssis - Selle et siège

52.5

1/1

1.9.1968



Fahrgestell - Sattel und Sitzbänke
 Chassis - Seat and seat bench
 Chassis - Selle et siège

52.5

Änderungen
 Modifications
 Modifications

1/1

1.9.1968

Änderung Nr.	Teil-Nr.	Stück/E						Sym- bol	Teil-Benennung	Denomination of parts	Dénomination de pièces	Änderung Nr.	Teil-Nr.	Bemerkungen
		R 26	R 27											
	46 54 5096136	1	1					Versteifungsbügel	Reinforcement bow	Etrier de renforcement				
	46 54 5096200	1	1					Gepäckträger	Luggage carrier	Porte - bagages				
	52 21 7002124	1	1					Abstandsrohr	Spacer tube	Tube d'ecartement				
	52 51 7002009	1	1					Fahrersattel	Driver's seat	Selle du conducteur				
	52 51 7002102	1	1					Zugfeder	Tension spring	Ressort de tension				
	52 51 7002116	1	1					Sattelträger	Seat carrier	Support de selle				
	52 51 7002141	1	1					Sattellager	Seat bearing	Coussinet de selle				
	52 51 7002123	1	1					Abstandsrohr	Spacer tube	Tube d'ecartement				
	52 51 7002137	1	1					Ringschraube	Ring screw	Vis à oeillet				
	52 51 9034015	1	1					„Pagusa“ Soziussitz	„Pagusa“ Pillion seat	Siège de passager „Pagusa“				
	52 51 9034017	1	1					Schutzblechsattel „Pagusa“	Fender seat „Pagusa“	Siège avec plaque de protect. „Pagusa“				
	52 53 9034020	1	1					Doppelsitzbank breit (USA)	Double seat bench large (USA)	Double siège, large (USA)				
	52 53 9034021	1	1					Doppelsitzbank schmal	Double seat bench small	Double siège, étroit				
	52 53 9034116	2	2					Seitenlasche	Side shackle	Equerre latéral				
	52 53 9034117	1	1					Gabellasche	Fork shackle	Etrier				
	07 11 9913457	2	2					Sechskantschraube M 6 x 15	Hex. head screw M 6 x 15	Vis à six pans M 6 x 15				
	07 11 9913471	2	2					Sechskantschraube M 6 x 18	Hex. head screw M 6 x 18	Vis à six pans M 6 x 18				
	07 11 9914057	1	1					Sechskantschraube	Hex. head screw	Vis à six pans				
	07 11 9914364	1	1					Sechskantschraube M 10 x 1 x 68	Hex. head screw M 10 x 1 x 68	Vis à six pans M 10 x 1 x 68				
	07 11 9921615	1	1					Sechskantmutter M 10 x 1	Hex. nut M 10 x 1	Ecrou à six pans M 10 x 1				
	07 11 9922054	4	4					Sechskantmutter M 6	Hex. nut M 6	Ecrou à six pans M 6				
	07 11 9922121	1	1					Sechskantmutter M 10 x 1	Hex. nut M 10 x 1	Ecrou à six pans M 10 x 1				
	07 11 9923414	2	2					Kronenmutter M 8	Castle nut M 8	Ecrou crénelé M 8				
	07 11 9931655	2	2					Scheibe 8,4	Washer 8,4	Disque 8,4				
	07 11 9936135	4	4					Zahnscheibe J 6,4	Shakeproof washer J 6,4	Disque denté J 6,4				
	07 11 9936225	1	1					Zahnscheibe J 10,5	Shakeproof washer J 10,5	Disque denté J 10,5				
	07 11 9945106	2	2					Splint 2 x 18	Split pin 2 x 18	Goupille 2 x 18				